

RC5032

5V to 3.3V Step-Down DC-DC Converter

Features

- >85% Efficiency
- Fast transient response
- Soft control power-up
- Short circuit protection
- Output voltage fixed 3.3V
- Low TC reference voltage
- Adjustable oscillator frequency
- Drives N-Channel MOSFET
- 8 pin SOIC, 8 pin DIP package

Applications

- 3.3V power supply for Pentium™ based desktop CPU motherboards
- Minimum component DC-DC converters

Description

The RC5032 is a step-down DC-DC controller IC dedicated to providing a 5V to 3.3V conversion for various types of CPU power. It can be configured with the proper applications circuitry to deliver load currents greater than 10 Amps. The RC5032 is designed to operate in a standard PWM control mode under heavy load conditions and as a PFM controller in light load conditions. Its highly accurate low TC reference

eliminates the need for precision external components in order to achieve tight tolerance voltage regulation.

The programmable oscillator can operate from 200KHz to greater than 1MHz to provide for flexibility in choosing external components such as inductors, capacitors, and Power MOSFETs.

Block Diagram

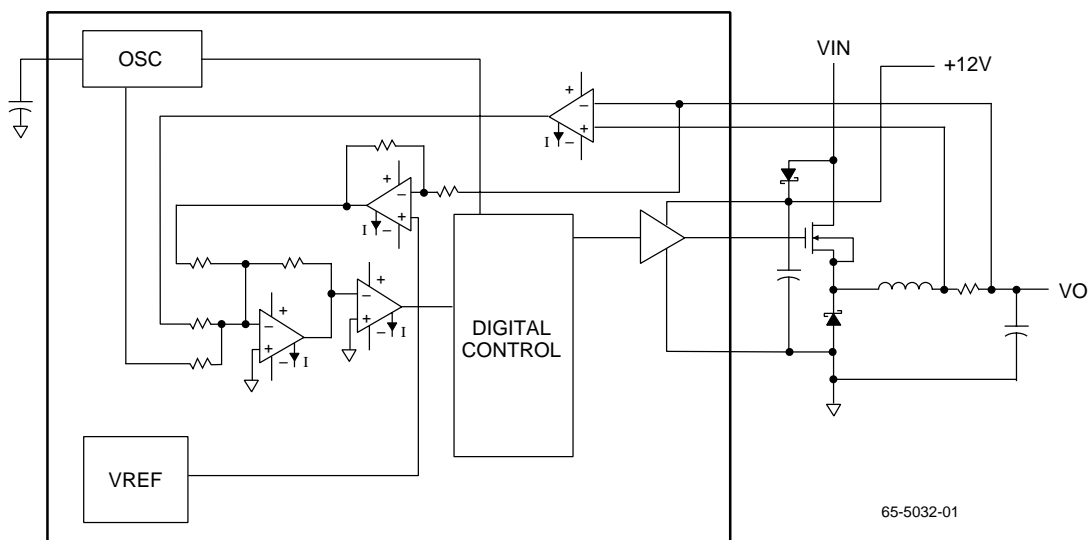

Preliminary Information

Pin Assignments

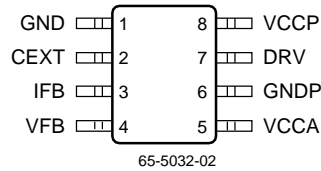

Pin Definitions

Pin Name	Pin Number	Pin Function Description
GND	1	Ground
CEXT	2	External capacitor for setting oscillator frequency
IFB	3	Current Feedback Input
VFB	4	Voltage Feedback Input
VCCA	5	Analog VCC
GNDP	6	Power ground for high current driver
DRV	7	FET Driver Output
VCCP	8	VCC for FET output drivers

Absolute Maximum Ratings

(beyond which the device may be damaged)¹

Parameter	Conditions	Min	Typ	Max	Units
VCCP	Driver Supply			13	V

Note:

- Functional operation under any of these conditions is NOT implied. Performance is guaranteed only if Operating Conditions are not exceeded.

Operating Conditions

Parameter	Conditions	Min	Typ	Max	Units
VCC	Supply Voltage	4.5	5	7	V
VCCP	Driver Supply	9		13	V
VIH	Input Voltage, Logic HIGH	2			V
VIL	Input Voltage, Logic LOW			0.8	V
	Ambient Temp	0		70	°C

Preliminary Information

DC Electrical Characteristics

($V_{CC} = 5V$, $F_{osc} = 650\text{ KHz}$, and $T_A = 0-70^\circ\text{C}$)

Parameter		Conditions	Min	Typ	Max	Units
V_O	Output Voltage		3.1	3.4	3.6	V
I_O	Output Current	See Figure 1 for application		7		A
$V_{ref\ Acc}$	Reference Accuracy			1	3	%
V_{TC}	Output Voltage TC			40		ppm
LDR	Load Regulation	0.5 to 7A		0.5		% V_O
LIR	Line Regulation	$V_{CC} = \pm 5\%$		0.07		% V_O
V_R	Output Voltage Ripple			30		mV
$Cum\ Acc$	Cumulative Accuracy ¹	$T_A = 0-70^\circ\text{C}$		3	5	%
Eff	Efficiency	$I_{load} > 4A$	85	88		%
I_{odr}	Output Driver I	Open Loop	0.5	0.7		A
P_d	Power Dissipation			0.1		W

Notes:

1. Output Voltage accuracy, Tempco, load regulation, ripple, and transient performance determine the Cumulative Accuracy.

AC Electrical Characteristics

($V_{CC} = 5V$, $F_{osc} = 650\text{ KHz}$, and $T_A = 25^\circ\text{C}$)

Parameter		Conditions	Min	Typ	Max	Units
T_r	Response Time	$I_L = 0.5A$ to $7A$		10		μs
F_{osc}	Oscillator Range		0.2		1.2	MHz
$Osc\ Acc$	F_{osc} Accuracy			10		%
D_{tc}	Max Duty Cycle	PWM mode	90	95		%
D_{tcm}	Min Duty Cycle	PFM mode			100	ns
I_{scp}	Short Circuit Prot			250		mV
T_{rimax}	Response to I_{max}			15	30	μs
T_{ssp}	Soft start response			1		ms

Test Circuit

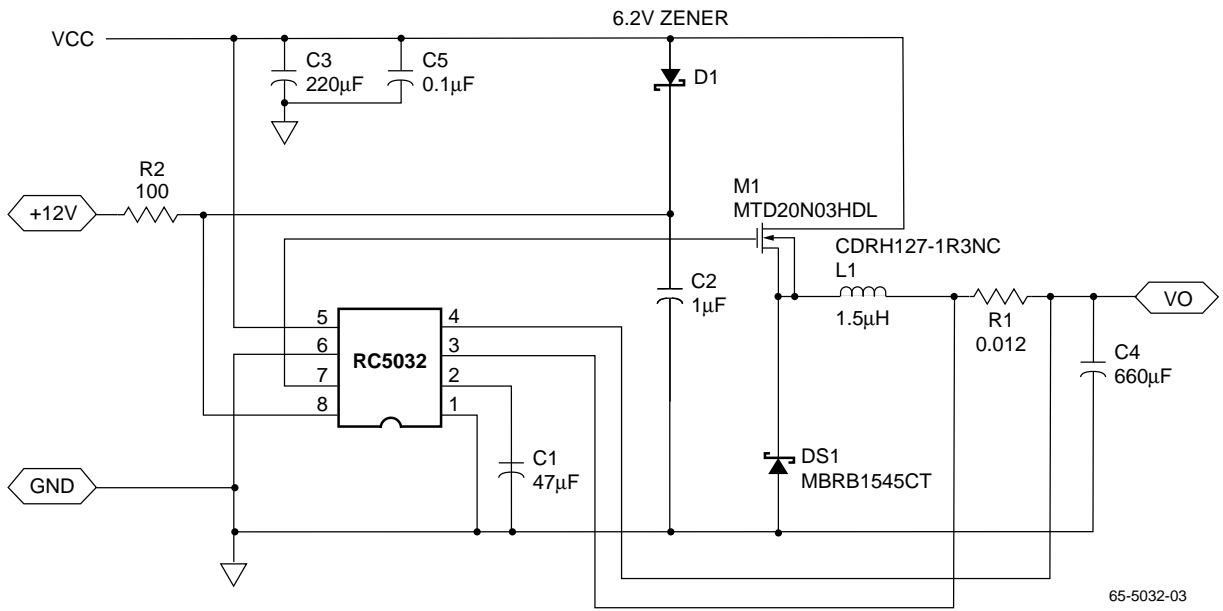

Figure 1. RC5032 7A Schematic

Table 1. Components for RC5032

RC5032 Standard Application Circuit Bill of Materials			
Ref Designator	Quantity	Part No.	Manufacturer
L1	1	CDRH127-1R3NC	Sumida
M1	1	MTD20N03HDL	Motorola
DS1	1	MBRB1545CT	Motorola
D1	1	6.2V Zener	any
R1	1	LRC-2512	IRC
C3	1	OS-CON 10SA220M	Sanyo
C4	2	OS-CON 10SA330M	Sanyo
C2	1	1uF	Monolithic ceramic Cap
C1	1	47pF	SMD Cap
C5	1	0.1uF	SMD Cap
R2	1	100Ω	SMD Res

Preliminary Information

Notes:

Preliminary Information

Mechanical Dimensions

8 Lead Ceramic DIP Package

Symbol	Inches		Millimeters		Notes
	Min.	Max.	Min.	Max.	
A	—	.200	—	5.08	
b1	.014	.023	.36	.58	8
b2	.045	.065	1.14	1.65	2, 8
c1	.008	.015	.20	.38	8
D	—	.405	—	10.29	4
E	.220	.310	5.59	7.87	4
e	.100 BSC		2.54 BSC		5, 9
eA	.300 BSC		7.62 BSC		7
L	.125	.200	3.18	5.08	
Q	.015	.060	.38	1.52	3
s1	.005	—	.13	—	6
α	90°	105°	90°	105°	

Notes:

1. Index area: a notch or a pin one identification mark shall be located adjacent to pin one. The manufacturer's identification shall not be used as pin one identification mark.
2. The minimum limit for dimension "b2" may be .023 (.58mm) for leads number 1, 4, 5 and 8 only.
3. Dimension "Q" shall be measured from the seating plane to the base plane.
4. This dimension allows for off-center lid, meniscus and glass overrun.
5. The basic pin spacing is .100 (2.54mm) between centerlines. Each pin centerline shall be located within ± 0.010 (.25mm) of its exact longitudinal position relative to pins 1 and 8.
6. Applies to all four corners (leads number 1, 4, 5, and 8).
7. "eA" shall be measured at the center of the lead bends or at the centerline of the leads when " α " is 90°.
8. All leads – Increase maximum limit by .003 (.08mm) measured at the center of the flat, when lead finish applied.
9. Six spaces.

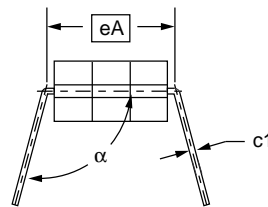
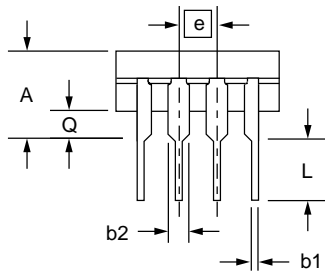
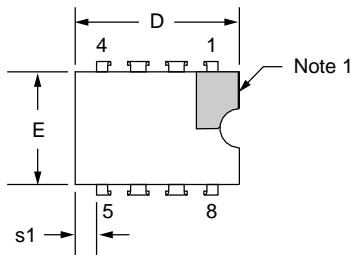

Preliminary Information

Mechanical Dimensions (continued)

8 Lead SOIC Package

Symbol	Inches		Millimeters		Notes
	Min.	Max.	Min.	Max.	
A	.053	.069	1.35	1.75	
A1	.004	.010	0.10	0.25	
B	.013	.020	0.33	0.51	
C	.008	.010	0.20	0.25	5
D	.189	.197	4.80	5.00	2
E	.150	.158	3.81	4.01	2
e	.050 BSC		1.27 BSC		
H	.228	.244	5.79	6.20	
h	.010	.020	0.25	0.50	
L	.016	.050	0.40	1.27	3
N	8		8		6
α	0°	8°	0°	8°	
ccc	—	.004	—	0.10	

Notes:

1. Dimensioning and tolerancing per ANSI Y14.5M-1982.
2. "D" and "E" do not include mold flash. Mold flash or protrusions shall not exceed .010 inch (0.25mm).
3. "L" is the length of terminal for soldering to a substrate.
4. Terminal numbers are shown for reference only.
5. "C" dimension does not include solder finish thickness.
6. Symbol "N" is the maximum number of terminals.

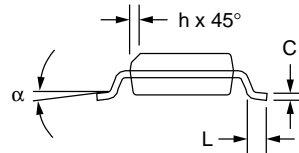
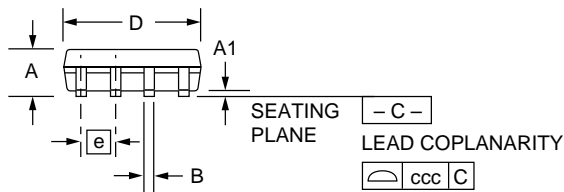
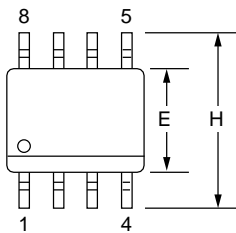

Ordering Information

Product Number	Package	θJA
RC5032M	8 SOIC	85°C/W

Preliminary Information

The information contained in this data sheet has been carefully compiled; however, it shall not by implication or otherwise become part of the terms and conditions of any subsequent sale. Raytheon's liability shall be determined solely by its standard terms and conditions of sale. No representation as to application or use or that the circuits are either licensed or free from patent infringement is intended or implied. Raytheon reserves the right to change the circuitry and any other data at any time without notice and assumes no liability for errors.

LIFE SUPPORT POLICY:

Raytheon's products are not designed for use in life support applications, wherein a failure or malfunction of the component can reasonably be expected to result in personal injury. The user of Raytheon components in life support applications assumes all risk of such use and indemnifies Raytheon Company against all damages.

Raytheon Electronics
Semiconductor Division
350 Ellis Street
Mountain View CA 94043
415 968 9211
FAX 415 966 7742